

HSF

NOTES:

Current Rating: 1.0AMP
 Contact Resistance: 20mΩ Max
 Withstand Voltage: 500V AC/DC
 Insulation Resistance: 1000MΩ Min
 Operation Temperature: -40°C to +105°C

Contact Material: Phosphor Bronze
 Contact plating: Au over Ni
 Insulator Material: PA9T+30%GF UL94V-0

Recommended P.C.B Layout (Top Side)
 (PCB BOARD TOLERANCE ±0.05)

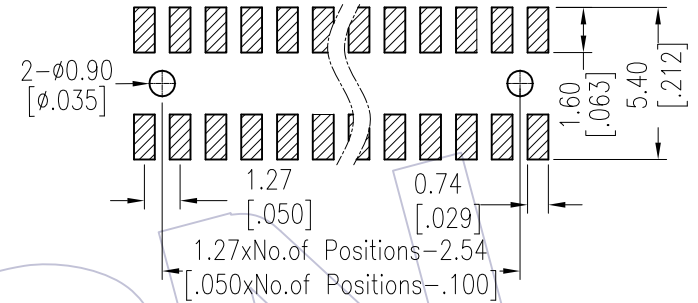
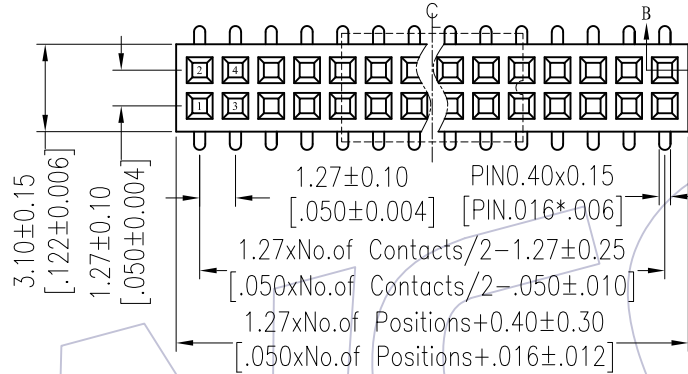

Ordering Information

2321-2 XX M XX CUN T X

No. of Pins per Row: 02-50 Pin

Contact Plating:
 G0=Gold Flash
 G3=10μ"Gold
 G4=15μ"Gold
 G5=30μ"Gold

Packing:
 T=Tube
 P=Tube+CAP
 R=Tape&Reel+CAP

Series No.
 1=Type 1
 2=Type 2

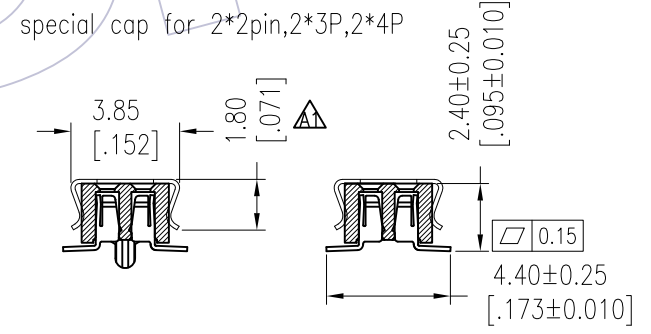
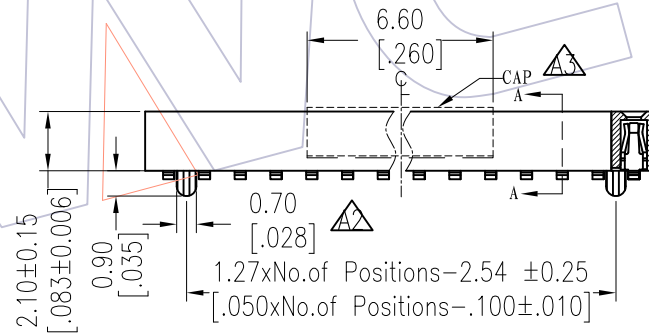

SECTION A-A



Item	Pitch	Mating
Standard	1.27	1310/1315/1320
Alternate		

TITLE	PART NO.
TYPE 1	2321-2XXMXXCUNT1
TYPE 2	2321-2XXMXXCUNT2

REV	DATE	MODIFICATION DESCRIPTION	CHANGE	OPERATION	DRAW	DATE	SCALE	FIT	PART NO.
A3	2014/12/30	Modify CAP	-----	OPERATION	Wang	2014/12/30	UNIT	mm	SEE TABLE
A2	2014/11/04	Modify Post	-----	x.X ±0.40	CHECK		SIZE	A4	TITLE: 1.27mm DUAL FEMALE HEADER SMT H=2.10
A1	2013/08/21	Modify cap 2.00 → 1.80	-----	x.XX ±0.25	APPROVE		SHEET	1/1	Customer NO.
A0	2012/07/06	NEW	-----	x.XXX ±0.15			PROJ.		
				Angle ± 3'					
				DIM TOL					

WCON
 Http: www.wcon.com

WCON-Dongguan
 Tel: +86 769 85358920
 Fax: +86 769 85358915
 E-mail: sales@wcon.com

WCON-Kunshan
 Tel: +86 512 57468408
 Fax: +86 512 57468468
 E-mail: salesks@wcon.com