

# HSF

**NOTES:**

Current Rating: 1.0AMP  
 Contact Resistance: 20mΩ Max  
 Withstand Voltage: 500V AC/DC  
 Insulation Resistance: 1000MΩ Min  
 Operation Temperature: -40°C to +105°C

Contact Material: Phosphor Bronze  
 Contact plating: Au over Ni  
 Insulator Material: PA9T+30%GF UL94V-0

Recommended P.C.B Layout(Top Side)  
 (PCB BOARD TOLERANCE±0.05)

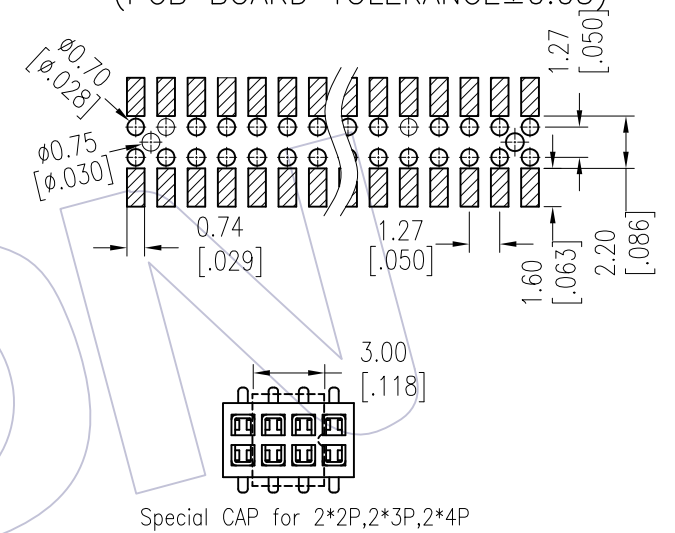
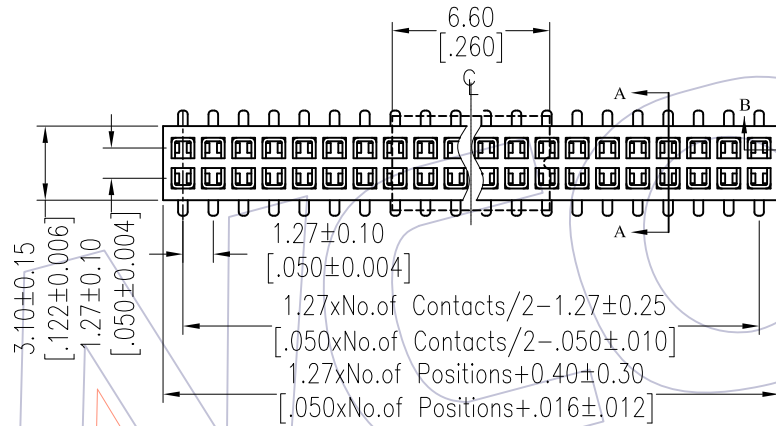

## Ordering Information

2320T - 2 XX M XX CUNT X

No. of Pins per ROW: 02-50PIN  
 Contact Plating: G0=Gold Flash, G3=10μ"Gold, G4=15μ"Gold, G5=30μ"Gold  
 Packing: T=Tube, R=Tape&Reel+CAP, P=Tube+CAP  
 Series No. 1=TYPE 1, 2=TYPE 2

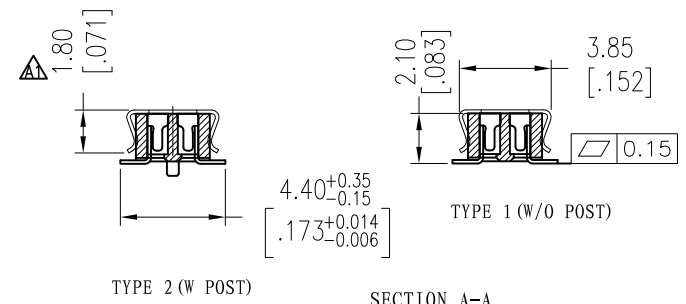
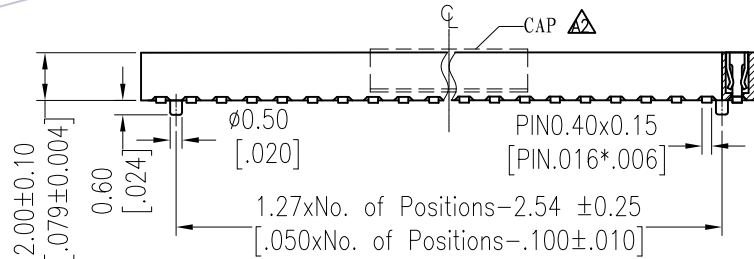

Item	Pitch	Mating
Standard	1.27	1310/1315/1320
Alternate		

TYPE	PART NO.
TYPE 1	2320T-2XXMXXCUNX1
TYPE 2	2320T-2XXMXXCUNX2

REV	DATE	MODIFICATION DESCRIPTION	CHANGE	OPERATION	DRAW Wang	DATE	SCALE	FIT	PART NO.
A2	2014/12/30	Modify CAP	-----	x.X ±0.40	Wang	2014/12/30	UNIT mm		SEE TABLE
A1	2013/08/20	Modify CAP 2.00 → 1.80	-----	x.XX ±0.25	CHECK	DATE	SIZE A4		TITLE: FH1.27mm Dual Bottom Enter SMT H=2.0
A0	2012/07/05	NEW	-----	x.XXX ±0.15	APPROVE	DATE	SHEET 1/1		Customer NO.
				Angle ± 3'			PROJ.		
				DIM TOL					

**WCON**  
 Http: www.wcon.com

WCON-Dongguan Tel: +86 769 85358920 Fax: +86 769 85358915 E-mail: sales@wcon.com

WCON-Kunshan Tel: +86 512 57468408 Fax: +86 512 57468468 E-mail: salesks@wcon.com